

EASTSIDE UTILITY DISTRICT

WATER LINE INSTALLATION

SPECIFICATIONS

AUGUST 2008

UPDATED 11-2016

These specifications provide guidance on the acceptable materials and their installation for developments inside the boundaries of Eastside Utility District. If there is something not covered, please bring it to our attention. Omission from these standards does not mean Eastside has no regulations regarding it.

Plans must be approved by the local governing body, the state of Tennessee, and Eastside Utility. Eastside reserves the right to disallow any contractor from working within its boundaries.

MATERIALS

DUCTILE IRON PIPE

Only Tyton Joint® ductile iron pipe manufactured by U.S. Pipe is allowed. This centrifugally cast ductile iron pipe, with Tyton joints complete with necessary gaskets and lubricant must be in accordance with ANSI/AWWA C151/A21.51-96 and ANSI/AWWA C111/A21.11-07 specifications. Pipe will be furnished cement lined per ANSI/AWWA C104/A21.4-03, seal coated inside and bituminous coated outside. Nominal 18-foot lengths accepted.

The following sizes and classes of pipe are allowable:

- 6" Class 350
- 8" Class 350
- 12" Class 350
- 16" Class 250
- 24" Class 250

FITTINGS

Fittings are to be:

- Ductile-iron (ANSI/AWWA C110/A21.10.03)
- Cement-lined (ANSI/AWWA C104/A21.4-03)
- Epoxy-coated (ANSI/AWWA C116/A21.16-03)
- Mechanical joint (ANSI/AWWA C111/A21.11-07)
- Compact (ANSI/AWWA C153/A21.53-06)
- Domestic

VALVES

The size and location of valves shall be shown on the accepted plans. All will be mechanical joint (except tapping valves that will be addressed later) according to ANSI/AWWA C111/A21.11-07 and ANSI/AWWA C550-05 specifications.

The gate valves are to be epoxy-coated and in accordance with ANSI/AWWA C509-01. They shall also be manufactured by either U.S. Pipe, Mueller, or M & H.

The butterfly valves are to be epoxy-coated and in accordance with ANSI/AWWA C504-06. They shall be manufactured by either U.S. Pipe, Mueller, M & H, or Clow. All valves shall be equipped with a two-inch (2") square operating nut and OPEN LEFT.

VALVE BOXES & LIDS

Acceptable valve boxes are the round, two-piece, screw-type, and either an 18" x 24" or 24" x 36" size. If neither size will work, a piece of 6" ductile iron pipe can be used in conjunction with a valve box collar and lid.

The lids should say "WATER" and fit in the top of the valve box or valve box collar.

FIRE HYDRANTS

Fire hydrants shall conform to the requirements of ANSI/AWWA C502-05 and be dry barrel. They shall be either a U.S. Pipe/Mueller M94 or M & H 129 with a 6" mechanical joint shoe and minimum 3 foot bury, more if necessary. Nozzle caps shall be provided with chains and gaskets. They shall be reverse threaded into the upper barrel and mechanically locked into place.

They shall have two 2-½" hose nozzles 180° apart and one 4-½" pumper nozzle. All nozzles shall be at the same elevation. The nozzle threads shall be National Standard Fire Hose Coupling Screw Thread as described in Appendix A of ANSI/AWWA C502-05 except for hydrants within the Chattanooga City limits. Contact the Chattanooga Fire Department for the specifications on their pumper nozzle threads.

The hydrants' color shall be dictated by the local governing body. If no preference is expressed, red is acceptable.

The operating nut shall be 1-½" point to flat. Hydrant shall OPEN LEFT. Shall also be the breakaway type, with a frangible ground line and rod coupling designed to break upon traffic impact and prevent further damage to the hydrant and its connection.

The location of the fire hydrants will be dictated on the plans approved by the state, Eastside, and local governing body.

TAPPING SLEEVES & VALVES

There are only two tapping sleeves that can be used to make a connection to an Eastside Utility water main. They are a U.S. Pipe T-9 or a Mueller H-615. However, the tapping valve can be from either manufacturer or from M & H. Tap shall be made by Eastside Utility.

FOSTER ADAPTERS

Foster adapters, a compact restraint device, shall be used to connect two mechanical joint pieces. They are typically used between a mechanical joint fitting and a mechanical joint valve but do have other applications. For more information, please visit www.infactcorp.com

BLOW OFF

They will consist of the plug (Trim Tyton with set screws and tapped 2"), two 2" x 6" and two 2" x 8" epoxy coated, ductile iron nipples, two 2" brass 90° bends, a 2" threaded valve (open left) with 2" operating nut, and a Gil Industries Post Flushing Hydrant. For more information visit www.gilindustries.com. These shall be constructed as shown in Figure 1. (If the ductile nipples are unavailable, use brass as galvanized is unacceptable.) All connections made using pipe joint compound.

FIELD LOK 350® GASKET

These gaskets, used for pipe restraint, are actually inserted into the bell of the pipe. They will be referred to as Field Lock for this standard. For more information, please visit www.uspipe.com.

MJ FIELD LOK®

This is another type of pipe restraint, similar to a mega lug. For more information, please visit www.uspipe.com.

AIR RELEASE

Used to release the air trapped in the water main during its installation. The size of the air release is dictated by the size of pipe being installed. There are two accepted models. The first is the Crispin AR Series. For more information, please visit www.crispinvalve.com. The second model is the APCO 50 or 200A series. For more information, please visit www.dezurik.com. They should be installed in a standard round meter box (plastic 18" tall with a black exterior and white interior and a cast iron lid) with a ¾" curb stop, either a Ford B44-333-Q or a Mueller B-25146, below it.

METER SETTINGS

Typically a one inch copper line is used to set two $\frac{3}{4}$ " meter settings. The following starts at the water main and goes through to the tail piece where the customer connects their service line.

The connection to the main water shall be made using a 1" corporation stop, either a Ford F1000-4-Q or Mueller H-15008. Type K copper tubing shall be used throughout. Next is a 1" x $\frac{3}{4}$ " Y; either a Ford Y44-243-Q or a Mueller H-15343. Typically one leg from the Y goes to a yoke while the other is stubbed out with a $\frac{3}{4}$ " curb stop, either a Ford B44-333-Q or a Mueller B-25146. The copper setter, or yoke, shall be either a Ford VBH71-7W-44-33-Q or a Mueller $\frac{5}{8}$ " x 7" 221B2470-R2. The meter box is a circular (18" tall) plastic one with a black exterior and white interior. The meter lid shall be cast iron. A tail piece will be left coming from the outlet side of the yoke and extending three feet past the customer's side of the box.

The yoke shall be centered in the meter box. No part of the yoke, especially the cutoff and check valve, shall be touching the meter box.

INSTALLATION

First and foremost, all items are to be installed per the manufacturer's specifications, AWWA standards, and in accordance with the plans approved by the state, Eastside, and the local governing body.

PIPE

All ductile iron pipe shall be installed according to ANSI/AWWA C600-05 standards. The minimum cover for the pipe is 30 inches of clean (no rocks, asphalt, etc.) dirt. If rock is encountered, the pipe shall be bedded in at least 6" inches of gravel and the ditch backfilled with gravel to a minimum depth of 12" above the top of the pipe.

Bends, other than 90°s, are not permitted unless Foster adapted to a valve which must be attached to a tee. If deflection is needed, short pieces of pipe must be cut and deflected to a maximum of 5° as per manufacturer's standards. These cuts are to be made square to the pipe. The spigot end is to be beveled using a grinder or other equipment sufficient to do such work.

When the water main is going to end at a blow off, a minimum of five Field Lock gaskets are to be used prior to the termination. Also, an adequate thrust block must be poured as shown in Figure 2. If it is a valve (stub out for future growth), a minimum of five full pieces of pipe will be installed past the termination point with a 4x4 installed vertically in the ground to mark the end unless otherwise noted on the plat. The end of the pipe must be securely sealed to keep it free of dirt, groundwater, and animals.

When an existing or proposed road is crossed via an open cut, it shall be back-filled in accordance with the local governing body. It is the contractor's responsibility to verify what the regulations are. Existing pavement shall be cut in neat, straight lines with either a pavement breaker or pavement saw and returned to its previous state.

If the use of steel casing (continuous weld construction and installed with welded joints) is necessary or dictated by the local authority, Field Lock gaskets shall be used inside. The appropriate spacers are to be used also. The company doing the bore must be approved by Eastside Utility.

The casing shall have minimum yield strength of 35,000 psi and minimum thickness:

<u>Pipe Diameter (inches)</u>	<u>Minimum Thickness (inches)</u>
≤12	0.188
16	0.219
24	0.344
30	0.406

It is also the contractor's responsibility to determine where the pipe is to be installed according to the centerline of the right of way. Consideration must be taken of sidewalks and other utilities.

When the water main is in the vicinity of a sewer, the following guidelines apply.

Parallel Installation

- a. Normal conditions – Water mains shall be laid at least 10 feet horizontally from any sanitary sewer, storm sewer, or sewer manhole, whenever possible; the distance shall be measured edge-to-edge.
- b. Unusual Conditions – When local conditions prevent a horizontal separation of 10 feet, a water main may be laid closer to a storm or sanitary sewer provided that:
 - The bottom of the water main is at least 18 inches above the top of the sewer
 - Where this vertical separation cannot be obtained, the sewer shall be constructed of materials and with joints that are equivalent to water main standards of construction and shall be pressure tested to assure water-tightness prior to backfilling.

Crossings

- a. Normal Conditions – Water mains crossing house sewers, storm sewers or sanitary sewers shall be laid to provide a separation of at least 18 inches between the bottom of the water main and the top of the sewer, whenever possible.
- b. Unusual Conditions – Water mains passing under sewers, shall, in addition, be protected by providing:
 - A vertical separation of at least 18 inches between the bottom of the sewer and the top of the water main;
 - Adequate structural support for the sewers to prevent excessive deflection of joints and settling on and breaking the water mains;
 - That the length of water pipe be centered at the point of crossing so that the joints will be equidistant and as far as possible from the sewer;
 - Both the sewer and the water main shall be constructed of water pipe.

Sewer Manholes – No water pipe shall pass through or come into contact with any part of a sewer manhole.

When a water main is to cross a body of water (creek, stream, lake, etc.) Field Lock gaskets are to be used throughout the crossing. Valves shall be provided at both ends of the crossing so that the section can be isolated for test or repair; the valves shall be easily accessible and not subject to flooding.

FITTINGS

Fittings are to be installed as shown on the plans. Any deviations must be approved beforehand by either the Eastside Utility General Manager or Inspector. Concrete thrust blocks are to be used as shown in Figure 2. Any time a thrust block is used, 5 Field Lock gaskets and either Mega Lugs or MJ Field Locks are to be installed as well. For a 90° bend, 5 Field Lock gaskets shall be installed on both sides of the fitting as well as either Mega Lugs or MJ Field Locks. Approved mechanical joint accessories (bolts, gaskets, and glands) are to be used.

VALVES

Gate valves, both mechanical joint and tapping, are to be installed per the requirements of ANSI/AWWA C509-01. Valves are to be installed, along with a valve box, such that a valve key can easily operate it after back-filling. The top of the valve box shall be flush with the finished grade. The locations, sizes, and types of the valves are dictated by the approved plans.

FIRE HYDRANTS

Each fire hydrant shall be installed in accordance with ANSI/AWWA C502-05. The assembly shall consist of a fire hydrant, a connector piece (MJ gland on one end and DI rotating MJ gland on the other end), a 6" MJ (isolation) valve, and MJ Fire Hydrant Tee. Erect the fire hydrant to stand plumb with the pumper nozzle facing the road. The weep holes are to be unobstructed. The location is dictated by the approved plans. The hydrant should be installed such that the lowest nozzle is at least 12 inches above finished grade. If extensions are needed, it will be the sole responsibility of the contractor to both purchase and install them.

TAPS

Taps are to be made by Eastside Utility. The tapping sleeve, tapping valve, their installation, and excavation are the responsibility of the contractor. For a fee, Eastside will air test the sleeve and valve as a whole and make the tap.

FOSTER ADAPTERS

Foster adapters are to be used in connecting two mechanical joint fittings. They are typically used between a tee and a valve but do have other uses.

BLOW OFFS

Blow offs are to be installed at the end of a line that has no provision to ever be extended. The approved plans will show their locations.

AIR RELEASES

Locations of the air releases will be determined during the job.

POST INSTALLATION

FLUSHING

Prior to pressure testing, the contractor shall flush the water mains in an effort to eliminate air pockets and remove particulates. The flushing velocity in the main shall not be less than 2.5 ft/sec. Note that flushing is no substitute for preventive measures during construction. Certain contaminants, such as caked deposits, resist flushing at any feasible velocity and pigging of the main may be required. The flushing shall be done in accordance with ANSI/AWWA C651-05.

When flushing, the contractor is do use Best Management Practice's that will allow the water to sheet flow over a vegetated area if possible, and not to cause erosion which in turn will cause fugitive sediment to be suspended. Please contact the Hamilton County Water Quality Program at 423-209-7851 or the Chattanooga office at 423-668-2530 if there is any uncertainty on handling the discharge.

PRESSURE TESTING

The contractor shall be responsible for the pressure testing of the water main.

Following the installation of any new pipeline, all newly laid pipe or any valved section thereof shall be subjected to a hydrostatic pressure test. Each valved section of pipeline shall be slowly filled with water. When venting air from pipelines, it is important to limit the pipeline fill rate to avoid excessive surge pressures when the water reaches the air venting opening(s). The specified test pressure shall be applied using a suitable pump connected to the pipeline. (NOTE: The test pressure shall not be less than 1.25 times the stated working pressure of the pipeline measured at the highest elevation along the test section and not less than 1.5 times the stated working pressure at the lowest elevation of the test section.) Before applying the specified test pressure, air shall be expelled completely from the pipeline section under test. The pipeline shall be allowed to stabilize at the test pressure before conducting the hydrostatic test. This may require several cycles of pressurizing and bleeding trapped air prior to beginning the test. The hydrostatic test shall be of a 24-hour duration with the results provided to Eastside Utility. The test pressure shall not vary by more than ± 5 psi for the duration on the test. Test pressure shall be re-established within this tolerance by adding makeup water through the pressure test pump into the pipeline. The amount of makeup water added shall be accurately measured (in gallons per hour) by suitable methods and shall not exceed the applicable testing allowance. No pipeline will be accepted if the quantity of makeup water is greater than that determined in the following chart:

Hydrostatic testing allowance per 1,000 feet of pipe (gph)

Avg Test Pressure <i>psi</i>	Nominal Pipe Diameter - <i>in.</i>						
	4	6	8	12	16	24	30
300	0.23	0.35	0.47	0.70	0.93	1.40	1.75
275	0.22	0.33	0.45	0.67	0.89	1.34	1.68
250	0.21	0.32	0.42	0.64	0.85	1.28	1.60
225	0.20	0.30	0.40	0.61	0.81	1.21	1.52
200	0.19	0.28	0.38	0.57	0.76	1.14	1.43
175	0.18	0.27	0.36	0.53	0.71	1.07	1.34

DISINFECTION

A newly installed main shall be disinfected in accordance with ANSI/AWWA C651. Section 4.4 discusses several acceptable methods. Following chlorination, the main should be flushed as soon as possible (within 24hr), because prolonged exposure to high concentrations of chlorine might damage the asphaltic seal coating.

BACTERIOLOGICAL TEST

The contractor is responsible for obtaining a clean bacteriological test from an approved laboratory. The report must be sent to Eastside Utility.

ONE YEAR WARRANTY

The contractor must guarantee the workmanship, including parts, for one year after the project ends. This includes, but not limited to, anything that was put in the ground. All meter boxes and valve boxes must remain flush with the ground and allow easy access.

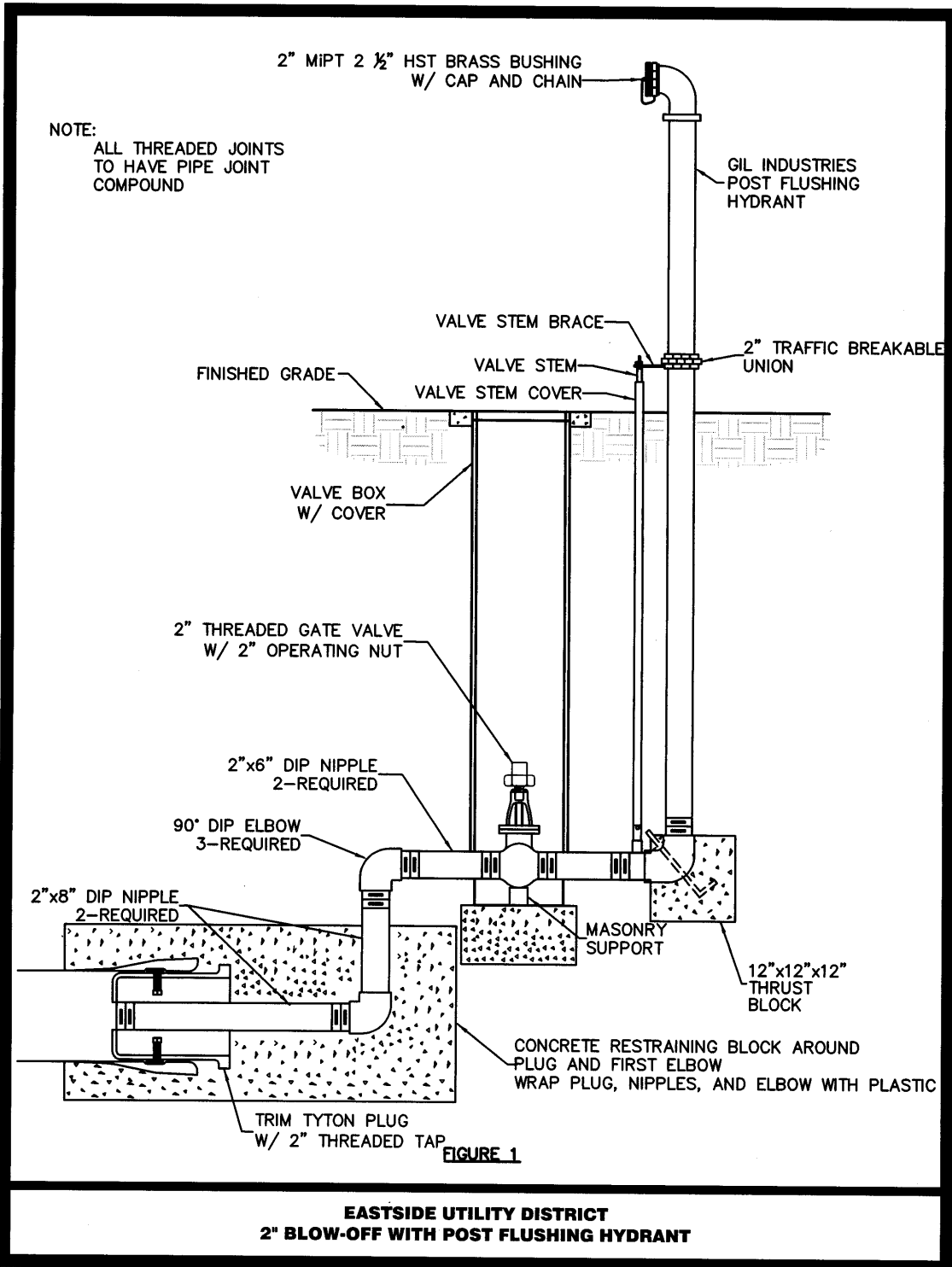

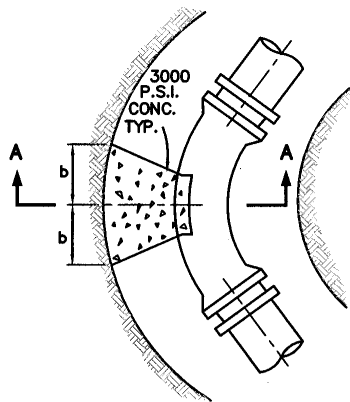

TYPICAL BEND PLAN

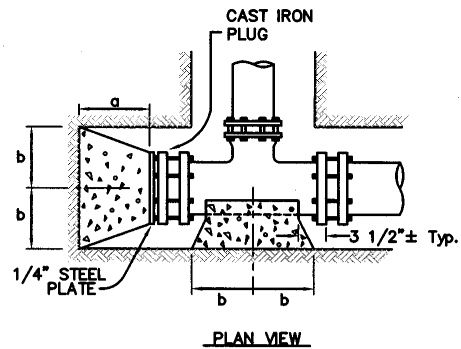

TEE AND DEAD END BLOCKING

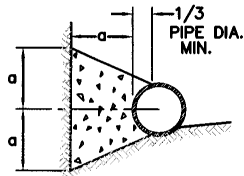

SECTION A-A

THRUST BLOCK DETAILS

NOTE:
 THRUST BLOCKS SIMILAR TO THOSE SHOWN SHALL BE CONSTRUCTED AT ALL TEES, BENDS, GATE VALVES, ETC. OF SUFFICIENT BEARING AREA TO RESIST PROBABLE MAXIMUM THRUST. SEE SPECIFICATIONS FOR DETAILS. DIMENSIONS BELOW ARE FOR SOILS WITH A BEARING CAPACITY OF AT LEAST 3000 P.S.F. AND A WATER PRESSURE OF NOT MORE THAN 150 P.S.I. IF A LOWER SOIL BEARING CAPACITY OR A HIGHER WATER PRESSURE IS ANTICIPATED, THE CONTRACTOR SHALL REQUEST THAT THE ENGINEER RESIZE THE THRUST BLOCKING.

MINIMUM THRUST BLOCK DIMENSIONS

PIPE SIZE	TEE		90° BEND		45° BEND		22 1/2° BEND	
	a	b	a	b	a	b	a	b
2"	2"	4.5"	2.5"	5"	2"	3.5"	1.5"	2.5"
3"	3"	6"	4"	6.5"	3"	5"	2"	3.5"
4"	4"	7.5"	5"	8.5"	4"	6"	3"	4"
6"	6"	10.5"	7.5"	12"	6"	8.5"	4.5"	5.5"
8"	8"	13.5"	10"	15"	8"	10.5"	6"	7"
10"	10"	17"	13"	18"	10"	13"	7.5"	9"
12"	12"	19.5"	15"	22"	12"	15"	9"	10.5"
16"	24"	32"	30"	34"	20"	30"	15"	20"
24"	30"	36"	36"	40"	24"	34"	18"	24"

FIGURE 2

**EASTSIDE UTILITY DISTRICT
 THRUST BLOCK DETAILS**

FIRE SPRINKLER SYSTEMS

1. The fire sprinkler system and the acceptance thereof by Eastside Utility is subject to the prior approval of the fire department having jurisdiction of the premises to be served. Also the *Application for Special Connection* must be completed before Eastside Utility will approve the plans.
2. That the entire private fire protection system on the premises shall be subject to the inspection, test and approval of Eastside Utility. Its representatives shall have the right to enter the premises at reasonable time for the purpose of making such reasonable inspections as it may deem necessary, and to insure compliance with the terms and conditions of its *Application for Special Connection*.
3. That all pipes and appurtenances shall be constructed and maintained in good condition by and at the expense of the Owner. All pipes and fittings shall be constructed of ductile iron from the Eastside Utility water main to the interior of the building and either ductile iron, copper, and/or steel from there.
4. That an AWWA approved backflow preventer (DDCA) and, if necessary, an AWWA approved fire line meter approved by both Eastside Utility and the fire underwriters, will be required on the service at a location approved by Eastside Utility. Such meter or device shall be installed and maintained by and at the cost and expense of the Owner, but subject to the inspection and approval of Eastside Utility. The by-pass meter only, used with the detector device, shall be furnished, installed and maintained by Eastside Utility at its cost and expense.
5. That a gate valve with post indicator controlling the entire supply shall be placed at the curb or property line of the street in which the main is located or at such other point as may be approved by Eastside Utility, and shall be furnished, installed and maintained by and at the expense of the Owner, and unless otherwise approved by Eastside Utility, said valve shall be installed in a valve pit or vault which shall be furnished, installed and maintained by and at the expense of the Owner.
6. That all hydrants and other fixtures connected to the private fire protection system shall be kept closed and sealed, and not opened or used except during times of fire or testing. Upon extinguishment of each fire or following each test, the Owner shall immediately close such fixtures and notify Eastside Utility so that they may be sealed. Whenever a private fire protection system is to be tested, the Owner shall notify Eastside Utility at least two business days in advance of such proposed test, requesting approval of the method, day, and hour on which it is to be made.
7. That no anti-freeze or any other substance, not specifically approved by the Environmental Protection Agency as non-detrimental to the public water supply, shall be introduced into sprinkling systems or into any pipe, fixture, appurtenance or other portion of the Owner's private fire protection service system.

8. That the Owner understands and agrees that the extent of the rights of the Owner under the *Application for Special Connection* is to receive, but only at times of fire on said premises, such supply of water as shall then be available and no other greater quantity. The Owner further acknowledges and agrees Eastside Utility shall not be considered in any way or manner an insurer of property or persons, or to have undertaken to extinguish fire or to protect any persons of property against loss or damage by fire, or otherwise, and Eastside Utility shall be free and exempt from any and all claims for damages on account of any injury to property or persons by reason of fire, water, failure to supply water or pressure, or any other cause whatsoever.
9. Any waste of water or use of water through this connection for purposes other than testing or the extinguishment of fire shall be deemed a violation of the rules, regulations and conditions of service of Eastside Utility.
10. That if private fire hydrants are included as part of this fire sprinkler system, they shall be painted any color other than that adopted by Eastside Utility for public fire hydrants.
11. That the Owner shall furnish, attach and make a part hereof, three (3) complete sets of drawings showing the pipes, pumps, valves, hydrants, sprinkler systems, hose outlets and connections, standpipes, tanks and other openings and appurtenances contemplated in this application. Such drawings, which shall be stamped "Approved" by the Insurance Services Office or other comparable agency approved by Eastside Utility, must also show all other water supply systems and pipelines and appurtenances which are proposed of which may exist on the premises to be served.
12. That no pipe, fixtures or appurtenances connected with the Owner's private fire protection service system shall be connected with any pipe, fixtures or appurtenances supplied with water from any other source, unless specifically approved in writing by Eastside Utility.
13. That the Owner agrees to obtain in advance the approval of Eastside Utility for any change, alteration, addition or deduction contemplated in the pipes, fixtures, openings and appurtenances and uses herein specified. Notwithstanding the approval of Eastside Utility, the Owner agrees that, except for those facilities which Eastside Utility has specifically agreed to provide and maintain, the Owner is and will be solely responsible for the design, adequacy, function and maintenance of its private fire protection system referred to in this application.
14. That Eastside Utility has the right to discontinue or disconnect the service pipe herein applied for, and to terminate service, after due written notice to the Owner, for failure to pay any bill when due, for leakage within the Owner's system, for violation of any other terms and conditions of the *Application for Special Connection*, or for any violation of its rules, regulations and conditions of service; and Eastside Utility also has the right to shut off all or any part of its facilities and discontinue the service without notice when deemed necessary by Eastside Utility (1) if a condition dangerous or hazardous to life, physical safety or property exists, (2) upon order by any court, the Department of Conservation and Environment or other duly authorized public authority, (3) if fraudulent or

unauthorized use of water by the Owner is detected, or if Eastside Utility's regulating or measuring equipment has been tampered with by the Applicant.

15. That upon acceptance of the *Application for Special Connection* by Eastside Utility and the completion of the installation of the service pipe applied for, this application shall be in full force and effect as a contract and shall continue as such until cancelled by written notice given thirty (30) days in advance by the Owner to the Eastside Utility, except as otherwise provided in numbered paragraph (14) above.
16. The acceptance of the *Application for Special Connection* by Eastside Utility must be executed by its Manager or Inspector before same becomes effective.